

Nera WorldPhone

IMPORTANT! When inserting a new battery or the battery is totally discharged, charge the battery for 2 minutes before turning ON the WorldPhone.

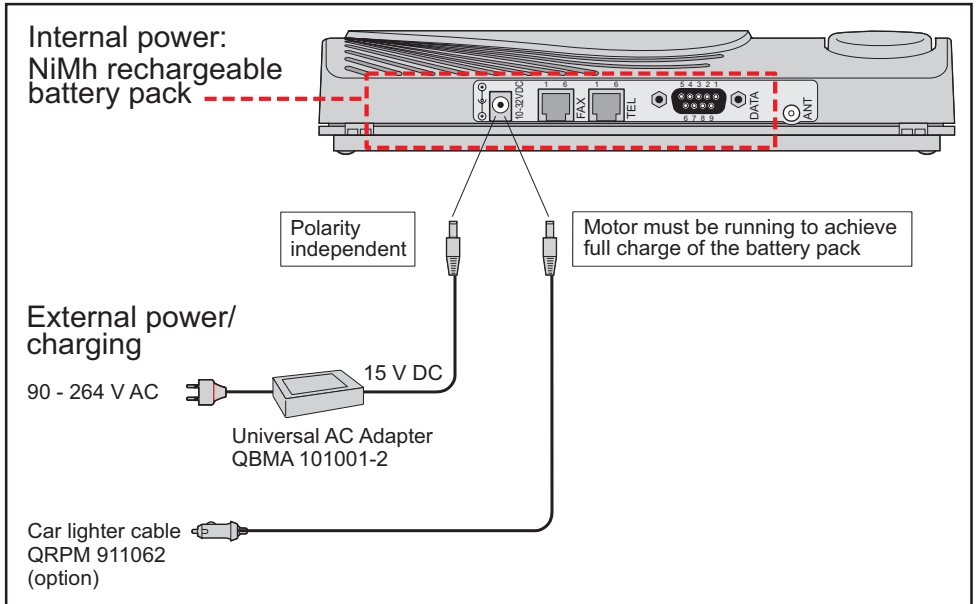

Handling

A new battery, or a battery that has not been used for a long time, will require 2 - 3 charge/discharge cycles to achieve its maximum performance with normal use of the WorldPhone.

To discharge the battery use the phone until it shuts down.

Avoid charging a fully charged or nearly charged battery.

Never leave the battery in hot sunlight. Extreme temperatures may cause permanent reduction of the battery capacity.